

# CDE Heated Cabinet



Made in Australia

## Standard Features

- **Durable welded stainless-steel frame** for lasting strength
- **Modern, frameless glass top and sides with a sleek integrated black edge finish** for clear product display from every angle
- **Removable non-tilt tray sliders** for easy maintenance
- **Bright top and front LED lighting** to showcase your food
- **Includes stainless steel wire racks** ready for display
- **Full-length polycarbonate hinged doors** for safe, everyday use
- **Digital temperature control** and display for precise heating
- **Balanced air circulation system** to maintain even temperature and freshness
- **Stainless steel base finish** as standard (custom finishes available)
- **Heavy-duty castors** allow effortless positioning, with two rear lockable wheels for stability
- **12 month warranty** parts and labour (excluding glass)



Model	Bays	Length	Width	Height	Shelving	Power
CDE750H	1	750mm	820mm	1275mm	6	1ph, 15Amp
CDE950H	1	950mm	820mm	1275mm	6	1ph, 15Amp
CDE1200H	1	1200mm	820mm	1275mm	12	1ph, 15Amp
CDE1475H	2	1475mm	820mm	1275mm	18	1ph, 2 x 15Amp
CDE1875H	2	1875mm	820mm	1275mm	12	1ph, 2 x 15Amp

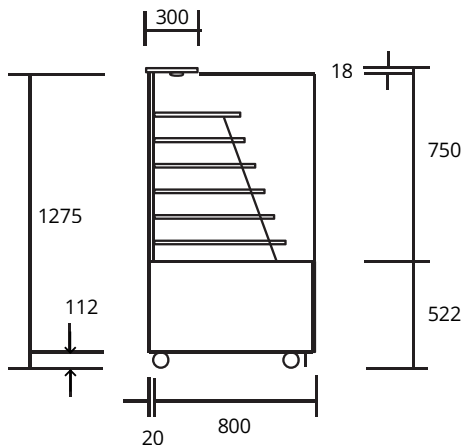

## Customise with Optional Extras

- **Extra wire shelving** (3-6 tiers) for increased display capacity
- **High-end custom finishes** available, including timber, stone, or laminate surfaces, with a wide range of Polytec® colour and style options to suit your shop decor
- **Curved glass front** for a premium look
- **Fixed under-shelf lighting per tier** to further enhance product visibility
- **Easy-glide, rear sliding doors** for quick access

**A premium heated display cabinet designed to showcase and hold hot food at serving temperature. Featuring sleek frameless glass, clean lines and seamless alignment across the Complete Display range, it combines visual impact for modern cafés, bakeries and takeaways.**



**Complete Display Equipment**  
5 Neutron Pl, Rowville VIC 3178



**1300 363 378**



**info@completedisplay.com.au**