

Refrigerated Cabinet Specification Sheet

Standard Features

- ✓ Stainless Steel Frames
- ✓ Clear View Curved or Square Glass
- ✓ Non Tilt Tray Sliders
- ✓ Choice of Castors or Legs
- ✓ Top and Front LED Lighting
- ✓ Choice of Many Standard Laminates
- ✓ Fan Assisted Air Circulation
- ✓ Digital Temp Control and Display
- ✓ New Cabinet Feature for Easy Cleaning
- ✓ Stainless Steel Trays or Chrome Wires Included
- ✓ Refrigerated Cabinets Have Slide out Refrigeration System



Also Available

- ✓ Glass Shelving
- ✓ New Square glass profile
- ✓ Extra Shelving
- ✓ Timber and Veneer Finishing
- ✓ Extra Wide Tops
- ✓ Front Rails
- ✓ Matching Till and Benches
- ✓ Under Shelf Lighting

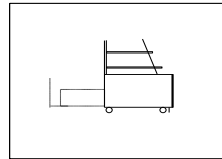

Slide out Refrigeration System

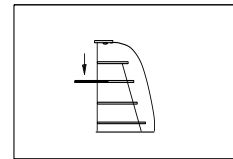

Non tilt tray supports

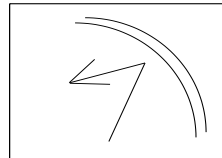

Double Glazed Low E Glass

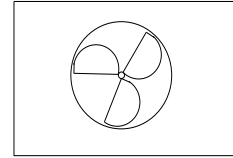

Fan assisted air circulation

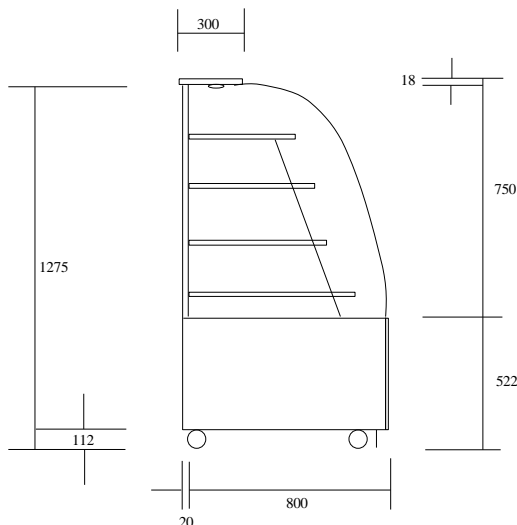

Dimensions

- 1 Module: 1200 x 820 x 1275
- 2 Module: 1610 x 820 x 1275
- 3 Module: 2375 x 820 x 1275

Power

Refrigerated Cabinets all 10 amp